

Optima® EAF-100 Faucet

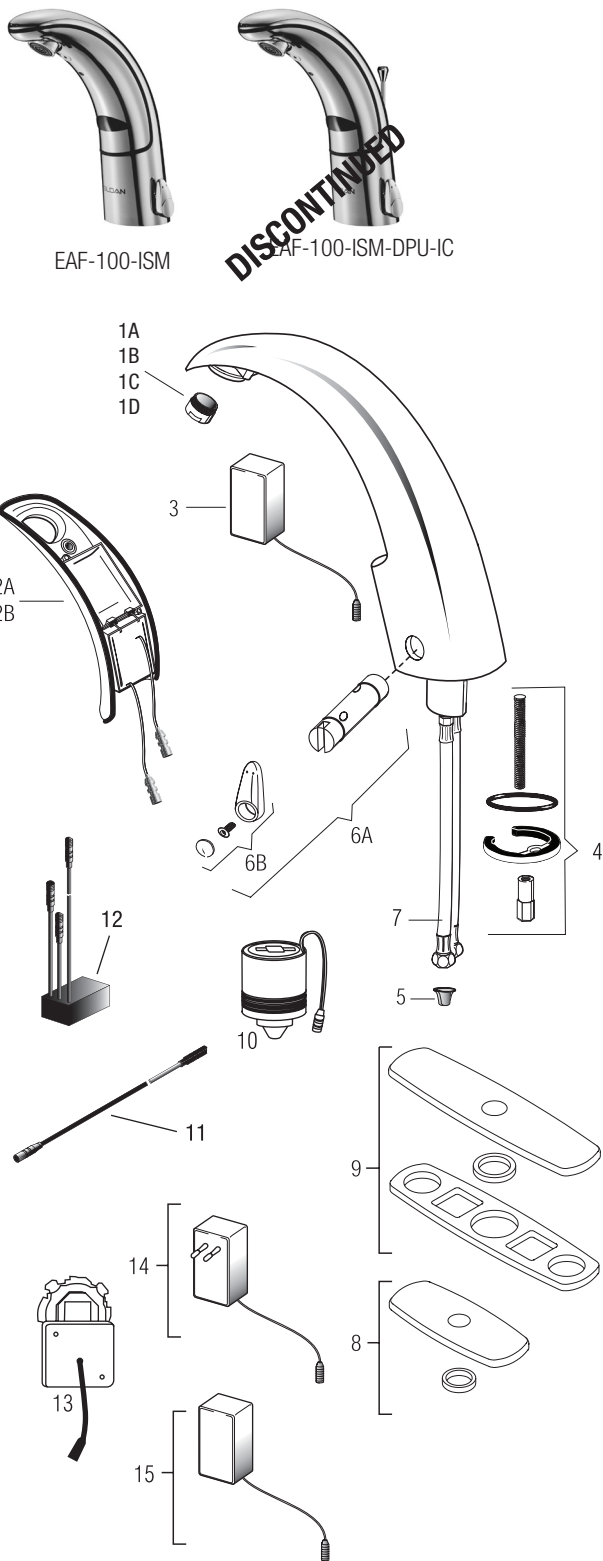

PARTS LIST — EAF-100 FAUCETS

Item No.	Code No.	Part No.	Description
1A.	0335021	EAF-22	1.5 gpm (5.7 Lpm) Aerator Spray Head
1B.	0335008	EAF-10	2.2 gpm (8.3 Lpm) Aerator Spray Head
1C.	0335010	EAF-12	0.5 gpm (1.9 Lpm) Multi-Laminar Spray Head
1D.	0335029	EAF-51	0.35 gpm (1.3 Lpm) Spray Head (Multi-Lam)
2A.	0335004	EAF-6-A	Sensor Throat Plate Assembly; Plug-in Faucet (Standard model with flush program button)
2B.	0335005	EAF-7-A	Sensor Throat Plate Assembly; Plug-in Faucet (IC model with protruding program button)
3.	0335009	EAF-11	100-240 VAC/6.75 VDC Plug-In Adapter (US)
4.	0335000	EAF-1	Faucet Mounting Kit
5.	0335007	EAF-9	Filter/Gasket for hose inlet (2 per pack)
6A.	3335118	EAF-1022-A	Side Mixer Cartridge & Handle
6B.	3335011	EAF-1002	Handle Repair Kit
7.	3335023	EAF-1008	15" (330 mm) Flexible Supply Hose (1)
8.	0362011	SFP-11	Trim Plate for 4" Center-set Sink
9.	3362022	SFP-22	Trim Plate for 8" Center-set Sink
10.	0335001	EAF-2	Solenoid (Solenoid (6 mm hex recess))
11.	0335024	EAF-24-A	11-13/16" (300 mm) Extension Cable
	0335025	EAF-25-A	47-1/4" (1200 mm) Extension Cable
	0335015	EAF-17-A	126" (3200 mm) Extension Cable
12.†	0335044	EAF-44	Power Splitter†, one (1) per faucet required
13.	0335037	EAF-37	6 VDC Box Mount Adapter 100-240 VAC/6.75 VDC
14.	0335038	EAF-38	90-264 VAC/6.75 VDC Plug-In Adapter (EURO)
15.	0335039	EAF-39	90-264 VAC/6.75 VDC Plug-In Adapter (UK)
16.	Not Shown		Back Checks inserted above hoses (ISM Faucets Only - Interchangeable)
	0335006	EAF-8	Back Checks, 2 pack (3/8" OD)
	3326044	MIX-79	Back Checks, 2 pack (3/8" OD)

† EAF-44 Power Splitter (12) replaces discontinued EAF28A capacitor & EAF23A splitter cable combination. EAF44 Power Splitter included with EAF-100 Faucet when ordered as -LT (Less Transformer) option. One (1) EAF-44 per faucet required.

EAF-1001 Mixer Handle Assembly and Cartridge (prior to 2004) Discontinued.
EAF100 faucets require EAF44 POWER SPLITTER in ganging (or daisy chain) application, one (1) per faucet.

Electrical Connection for up to Six (6) Faucets Using One (1) Adapter

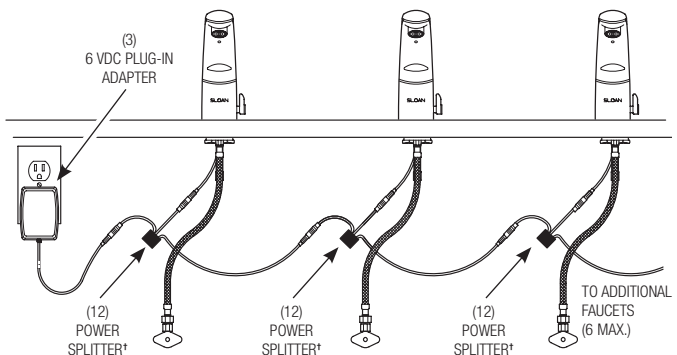

* EAF-100 faucets require use of EAF-44-A (12) Power Splitter in Ganging (Daisy Chain) Applications, one (1) per faucet. When ordering EAF100 faucets, "-LT" version (Less Transformer) includes one (1) EAF-44 power splitter.

Optima® EAF-100 Faucet

AUTO SENSOR CALIBRATION OR RANGE ADJUSTMENT

For sensor recalibration, press and release iq button 2 quick times, wait for rapid "temporary off" red LED flashes, then press and hold iq button for several seconds and after four (4) slow red LED flashes, release button and step away for fifteen (15) seconds to allow faucet sensor to recalibrate.

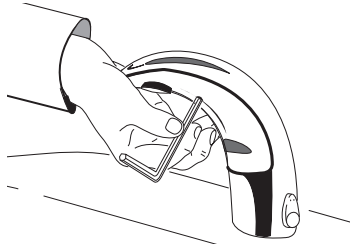

STANDARD MODELS

After water turns on then off and red LED flashes are followed by a single green flash (calibration complete), test faucet.

MANUAL RANGE ADJUSTMENT

To manually change range, press and release iq button 2 quick times, wait for rapid "temporary off" red LED flashes, then press and hold iq button, there will be four (4) red LED flashes, a pause, then more red LED flashes (up to eight (8) red LED flashes); 1-red LED flash for the shortest range setting, eight (8) flashes for the longest range setting;

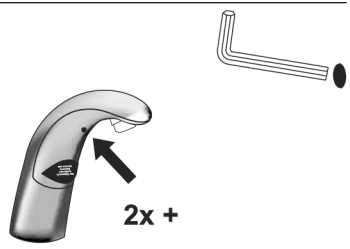

Release iq button after desired red LED flash for range setting (#6 is factory setting).

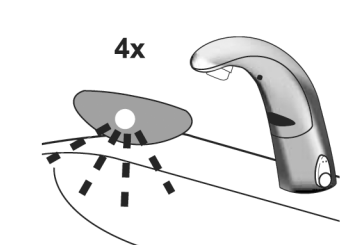

After releasing button, faucet will cycle through auto calibration (approximately 15-seconds). Then test faucet.

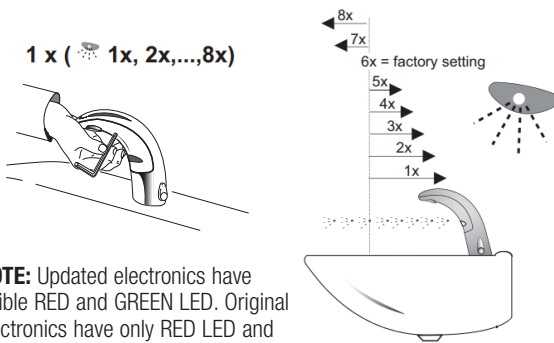

NOTE: Updated electronics have visible RED and GREEN LED. Original electronics have only RED LED and range setting is reversed (1 = longest, 8 = shortest)

SERVICE OPERATION

Prepare for operation

A. Press the button once.

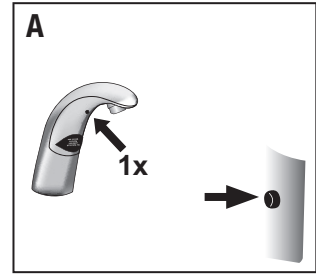

B. Remove sticker.



C. Water will flow 4 seconds



D. Wait 10 seconds, then the faucet is ready for use.

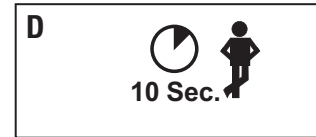

If waterflow doesn't start after removing the sticker and the red led within the sensor flashes continue with the following procedure!!

A. Press the button once.

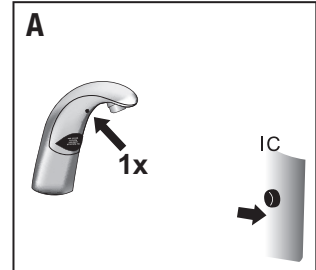

B. Hold a white sheet of paper 1.5" (40 mm) in front of sensor until water flows for 4 seconds

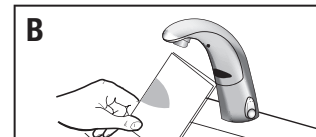

C. Remove paper.



D. Wait 10 seconds, then the faucet is ready for use.



Optima® EAF-100 Faucet

TROUBLESHOOTING GUIDE

1. Faucet DOES NOT function.

- A. Adhesive packaging label affixed over sensor eye. Remove adhesive label from sensor eye.
- B. "Permanent Off" activated. Press button on faucet throat one time.

2. Faucet delivers water in an uncontrolled manner.

- A. Faucet is not working properly. Contact Sloan Technical Support.

3. Faucet does not deliver any water when sensor is activated.

INDICATOR: Solenoid valve produces an audible "CLICK."

- A. Water supply stop(s) closed. Open water supply stop(s).
- B. Water supply stop strainer(s) clogged. Clean water supply stop strainer(s).

INDICATOR: Solenoid valve DOES NOT produce an audible "CLICK."

- A. Power failure (EAF-100 Models). Check power supply.

4. Faucet delivers only a slow flow or dribble when sensor is activated.

- A. Water supply stop(s) are partially closed. Completely open water supply stop(s).
- B. Water supply stop strainer(s) clogged. Remove, clean, and reinstall water supply stop strainer(s). Replace strainer(s) if required.
- C. Aerator is clogged. Remove, clean, and reinstall aerator. Replace aerator if required.
- D. Faucet is not working properly. Contact Sloan Technical Support.

5. Faucet DOES NOT stop delivering water or continues to drip after user is no longer detected.

- A. Clean Solenoid Valve - Turn off water, remove and unplug sensor/throat plate assembly with 2.5-mm hex wrench, remove solenoid using 6-mm hex wrench, clean solenoid diaphragm of plumbing debris, clean solenoid base in faucet with a dry towel, install solenoid (do not over-tighten), connect sensor/throat plate and install, dry fire solenoid (listen for clicking), then turn on water and test faucet. Also flush lines at stops as well to remove any plumbing debris in the line, check supply hose filters at that time as well.

6. i.q.-cliq DOES NOT function (-IC models only)

- A. Button is not working properly. Contact Sloan Technical Support.

7. The water temperature is too hot or too cold on a faucet connected to hot and cold supply lines.

- A. Supply stops are not adjusted properly. Adjust supply stops.
- B. For models with integral mixing valve — mixing valve is set improperly for the water temperature desired. Rotate mixing valve handle clockwise to decrease water temperature or counterclockwise to increase water temperature.

CARE AND CLEANING

DO NOT USE abrasive or chemical cleaners (including chlorine bleach) to clean faucets that may dull the luster and attack the chrome or special decorative finishes. Use **ONLY** mild soap and water, then wipe dry with clean cloth or towel. While cleaning the bathroom tile, protect the faucet from any splattering of cleaner. Acids and cleaning fluids will discolor or remove chrome plating.

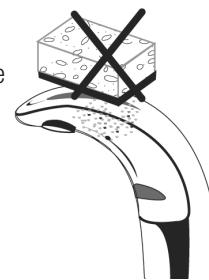

When assistance is required, please contact Sloan Technical Support at: 1-888-SLOAN-14 (1-888-756-2614).